

# CME650R SERVICE PARTS

This section contains the parts illustrations and parts lists for the CME650R.

CME650R ice machines are manufactured in both single and three phase. When ordering electrical parts, be certain to match the voltage to the ice machine.

Example:

CME650RE-32A is a single phase machine.

CME650RE-3A is a 3 phase machine.

A "no number" designation, when found in the part number column, indicates the part in question is not available from Scotsman as an assembly. This designation is used only for clarity in making the list. When ordering parts, to avoid costly delays and errors, give the part number, the complete description as shown in the list, and the quantity of each part or assembly required.

## TABLE OF CONTENTS

Exterior Panels . . . . .	2
Interior Panels . . . . .	3
Refrigeration System . . . . .	4
Water System . . . . .	5
Control Box . . . . .	6
Remote Condenser . . . . .	7
Wiring Diagrams . . . . .	8

# CME650R SERVICE PARTS CABINET ASSEMBLY

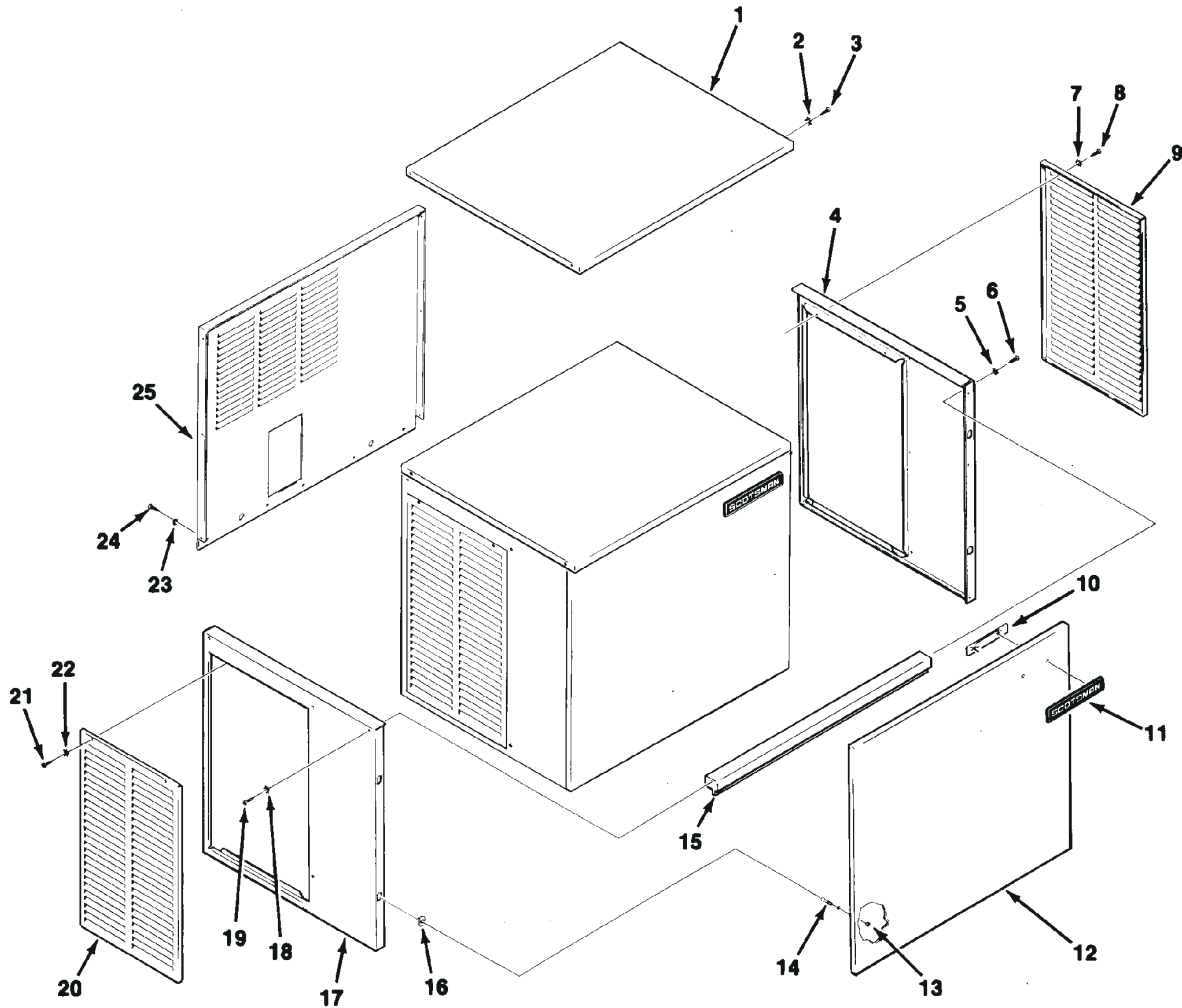

ITEM NUMBER	PART NUMBER	DESCRIPTION	ITEM NUMBER	PART NUMBER	DESCRIPTION
1	A32159-001	Top Panel, Painted	13	03-1406-04	Nut
	A32159-002	Top Panel, S. S.	14	15-0411-00	Strike
2	03-1417-27	Lockwasher	15	A32169-001	Front Support
3	03-1531-01	Screw	16	02-0836-00	Cabinet Catch
4	A32162-001	Right End Panel, Paint	17	A32163-001	Left End Panel, Paint
	A32162-002	Right End Panel, S.S.		A32163-002	Left End Panel, S.S.
5.	03-1417-27	Lockwasher	18	03-1417-27	Lockwasher
6	03-1531-01	Screw	19	03-1531-01	Screw
7	03-1417-27	Lockwasher	20	A32161-001	Service Panel, sandalwood
8	03-1404-12	Screw		A33946-032	Service Panel, gray
9	A32161-001	Service Panel, Painted	21	03-1404-12	Screw
	A33946-002	Service Panel, gray	22	03-1412-27	Lockwasher
10	03-0271-00	Speed Nut	23	03-1417-27	Lockwasher
11	15-0711-01	Emblem for painted	24	03-1531-01	Screw
	15-0808-01	Emblem for stainless steel	25	A32201-003	Back Panel for painted
12	A32160-001	Front Panel, Painted		A32201-002	Back panel for stainless
	A32160-002	Front Panel, S.S.			

# CME650R SERVICE PARTS CABINET INTERIOR

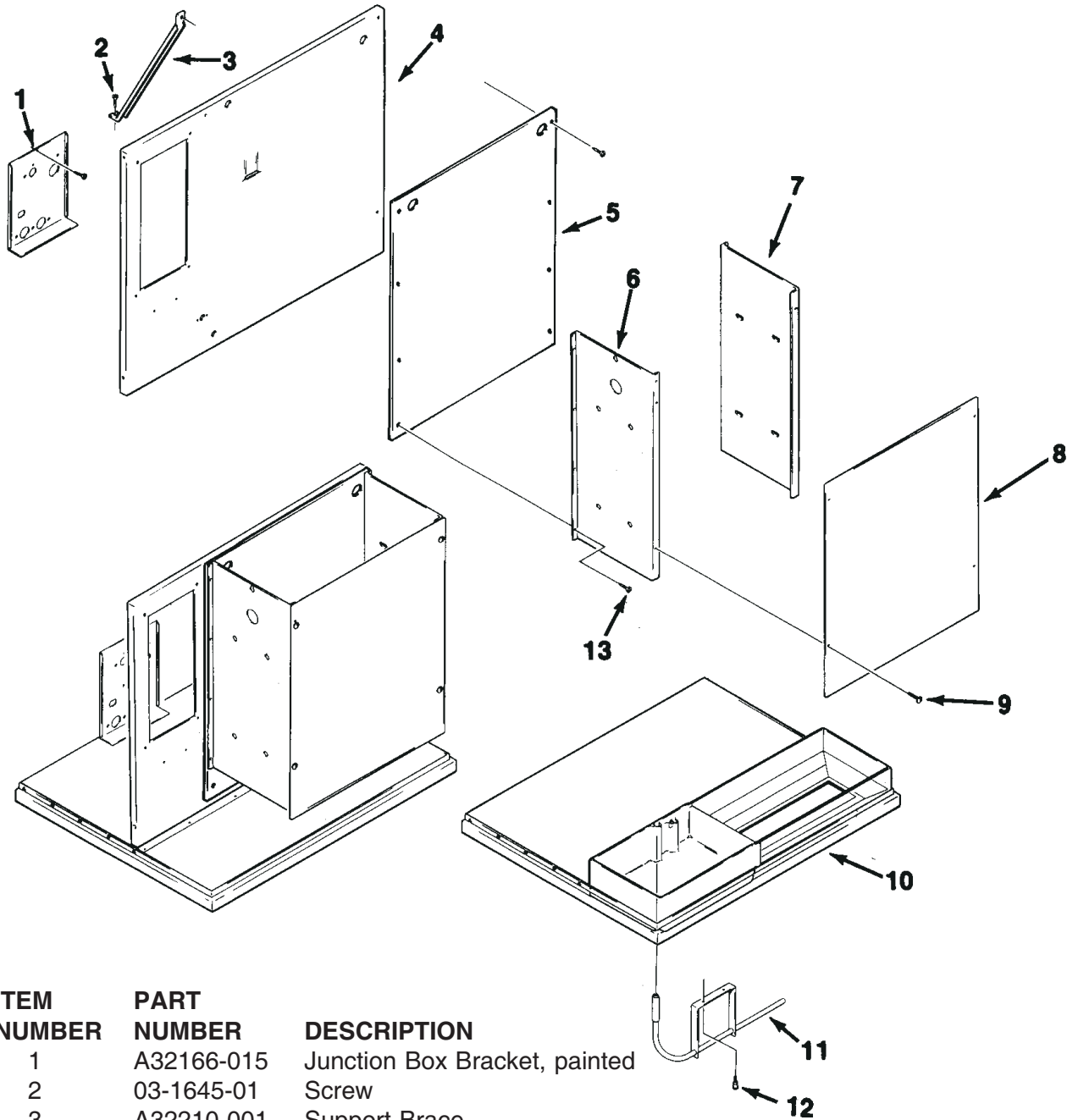

ITEM NUMBER	PART NUMBER	DESCRIPTION
1	A32166-015	Junction Box Bracket, painted
2	03-1645-01	Screw
3	A32210-001	Support Brace
4	A35666-001	Retainer
5	02-2867-01	Splash Panel
6	A35671-001	Evaporator Bracket, Left
7	A32172-001	Evaporator Bracket, Right
8	02-3246-01	Evaporator Plate Cover
9	03-0727-09	Thumbscrew
10	A32153-002	Base
11	A32262-001	Bin Thermostat Bracket
12	03-0727-09	Thumbscrew
13	03-1531-01	Screw

# CME650R SERVICE PARTS REFRIGERATION

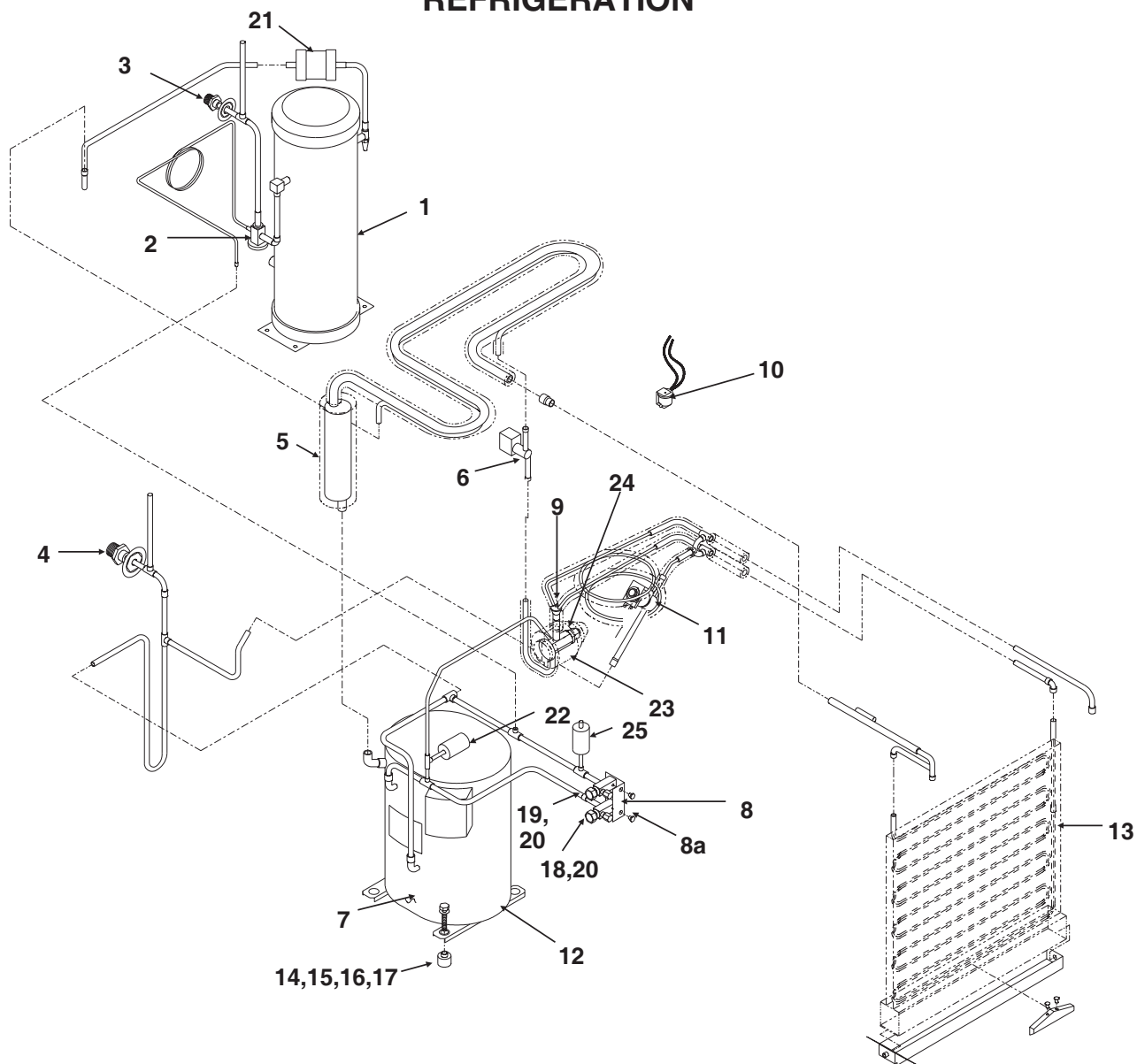

ITEM NUMBER	PART NUMBER	DESCRIPTION	ITEM NUMBER	PART NUMBER	DESCRIPTION
1	16-0761-01	Receiver	13	A30296-020	Evaporator
2	11-0422-24	Disch press. control valve	14	18-2200-28	Grommet
3	16-0850-03	Quick connect fitting, 3/8"	15	18-2200-27	Sleeve
4	16-0850-01	Quick connect fitting, 1/2"	16	03-1407-07	Washer
5	A35841-001	Heat exchanger	17	03-1405-20	Screw
6	12-2135-22	Liquid line solenoid valve	18	16-0832-20	Lo side access valve (w/caps)
7	12-2308-01	Crankcase heater	19	16-0832-21	Hi side access valve (w/caps)
8	A35588-001	Bracket for valves	20	16-0832-02	Stem cap
8a	03-0571-02	Screw for valves		16-0832-03	Core cap
9	16-0844-01	Distributor, includes tubes	21	02-3319-02	Drier
10	12-2300-03	Hi Temp Cut Out	22	11-0484-21	Pump down pressure switch
11	12-2417-23	Hot Gas Valve with coil	23	A36067-001	TXV insulation
12	18-8726-23	208-230/60/1 Compressor	24	16-0867-22	TXV
	18-8726-25	208-230/60/3 Compressor	25	11-0485-21	Hi Pressure Cut Out Switch

Compressors include drier, Overload is internal

# CME650R SERVICE PARTS WATER SYSTEM

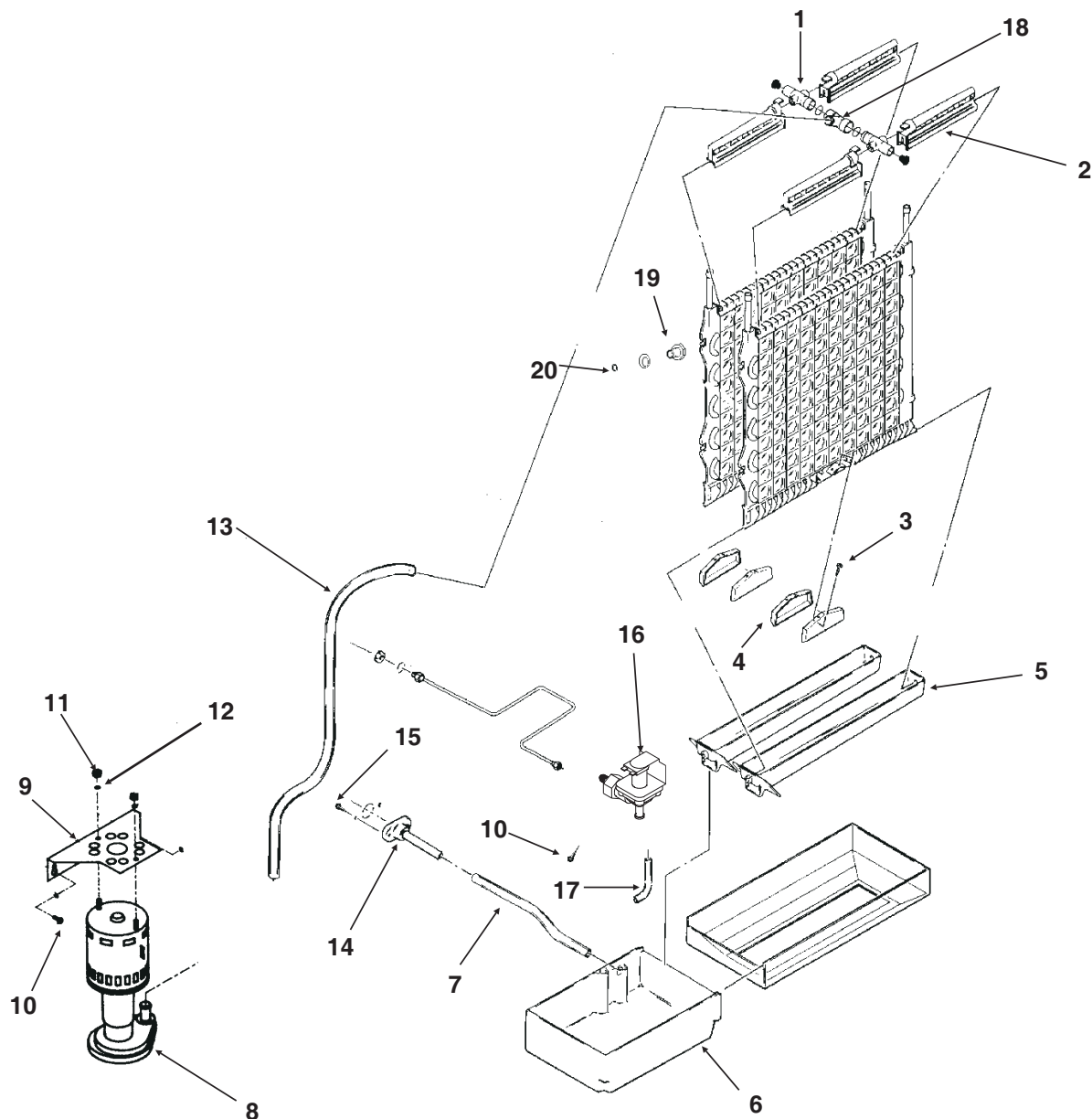

ITEM NUMBER	PART NUMBER	DESCRIPTION	ITEM NUMBER	PART NUMBER	DESCRIPTION
1	A29703-001	Manifold	13	13-0674-07	Pump hose, 33"
2	02-2527-01	Water distributor tube	14	A32282-003	Drain assembly
3	03-1531-01	Screw	15	03-1645-01	Screw
4	02-2878-01	End cover	16	12-2446-24	Inlet water valve
5	02-2868-01	Drain trough	17	A35926-001	Water inlet tube
6	02-2869-01	Reservoir	18	02-2519-01	Tee
7	13-0674-07	Drain hose, 8"	19	02-2642-01	Plate mount
8	12-2265-22	Water pump	20	03-1394-03	Pal nut
9	A35554-015	Pump bracket			
10	03-1531-01	Screw			
11	03-1406-05	Nut			
12	03-1417-06	Lockwasher			

# CME650R SERVICE PARTS CONTROL BOX

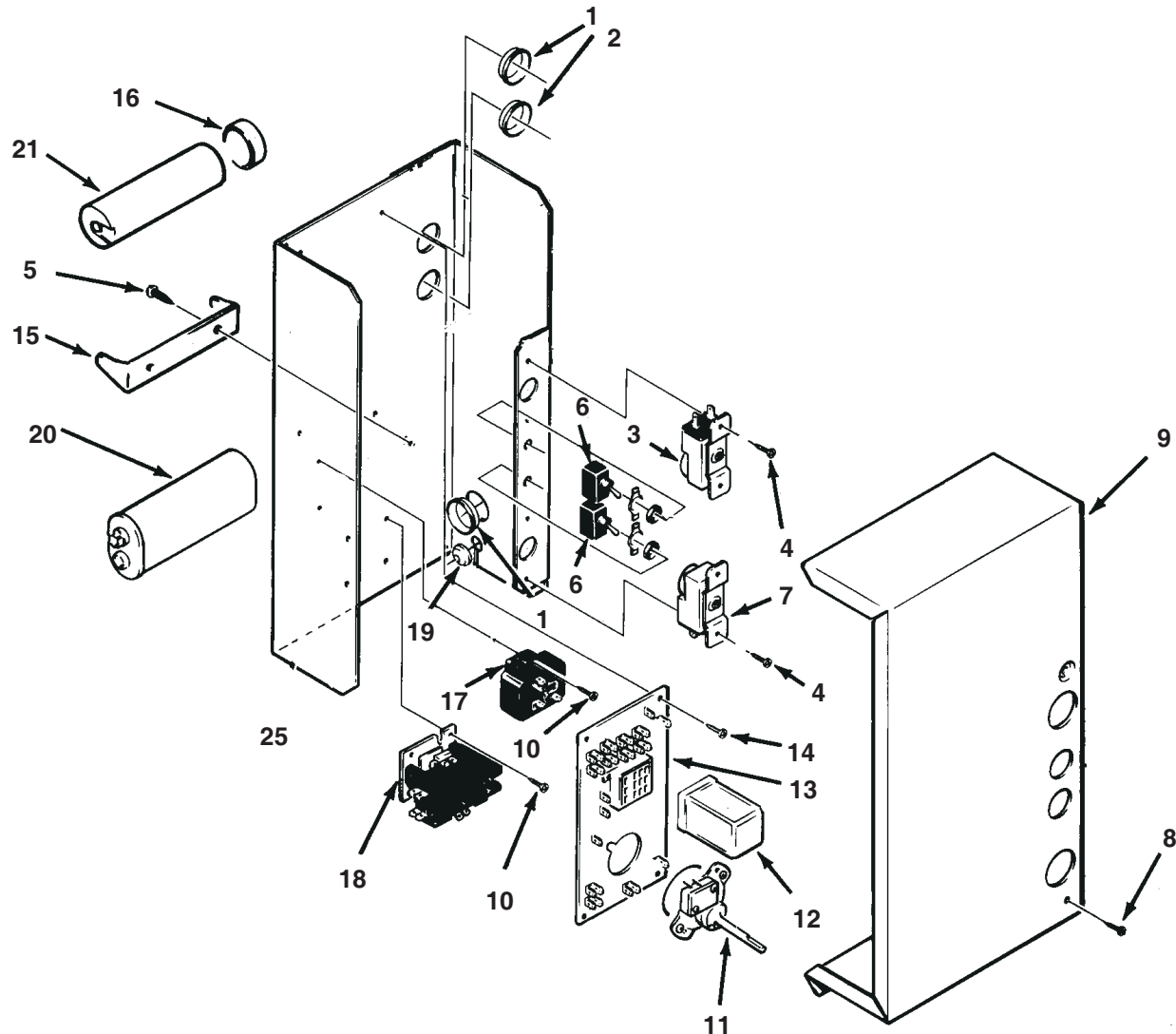

ITEM NUMBER	PART NUMBER	DESCRIPTION	ITEM NUMBER	PART NUMBER	DESCRIPTION
1	12-1213-17	Snap bushing	16	18-2200-38	Cap for start capacitor
2	12-1213-10	Snap bushing	17	18-1903-33	Potential relay
3	11-0435-21	Cube size thermostat	18	12-2469-02	Contactor for single phase
4	03-1403-17	Screw	12-0739-02	Contactor for 3 phase	
5	03-1418-06	Screw	19	12-1213-04	Snap bushing
6	12-0426-01	Toggle switch	20	18-1902-53	Run capacitor
7	11-0427-22	Bin thermostat	13-0666-00	Cap for run capacitor	
8	03-1531-01	Screw	A32872-001	Clamp for run capacitor	
9	A32168-001	Control Box Cover	21	18-1901-15	Start capacitor
10	03-1638-03	Screw			
11	12-2317-22	Timer & Switch			
12	12-1879-03	Relay			
13	12-1912-01	Circuit Board			
14	03-1403-02	Screw			
15	18-2200-39	Bracket for start capacitor			

# CME650R SERVICE PARTS REMOTE CONDENSER

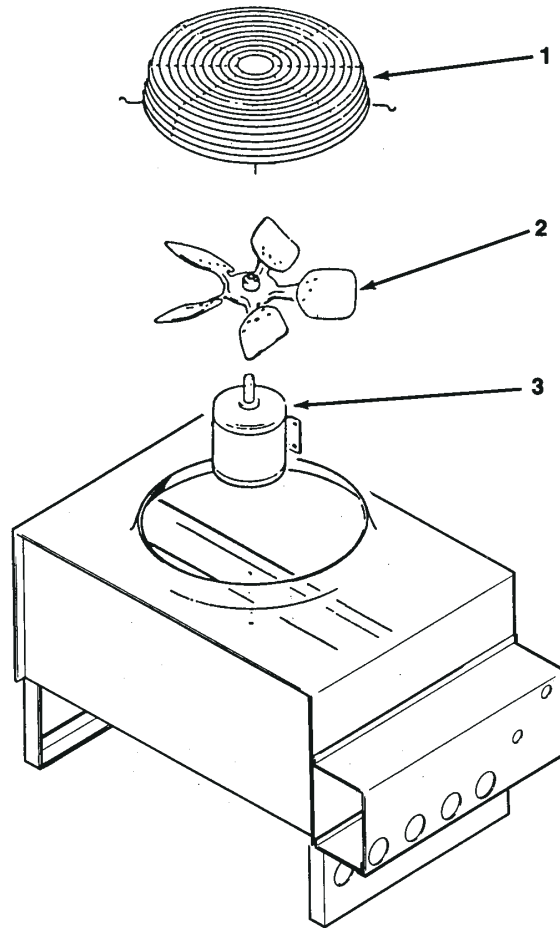

**RCE651 or RCE652**

ITEM NUMBER	PART NUMBER	DESCRIPTION
1	02-2618-01	Fan Guard
2	18-6304-01	Fan Blade
3	18-5301-01	Fan Motor

For Pre Charged Line Set

4	16-1057-01	Female coupling (3/8")
5	16-1057-02	Female coupling (1/2")

**ERC201 or ERC402**

1	02-3575-01	Fan guard
2	18-8800-01	Fan blade
3	18-8796-32	Fan motor

# CME650R SERVICE PARTS

## Single Phase WIRING DIAGRAM

A35941-032

THIS UNIT MUST BE GROUNDED

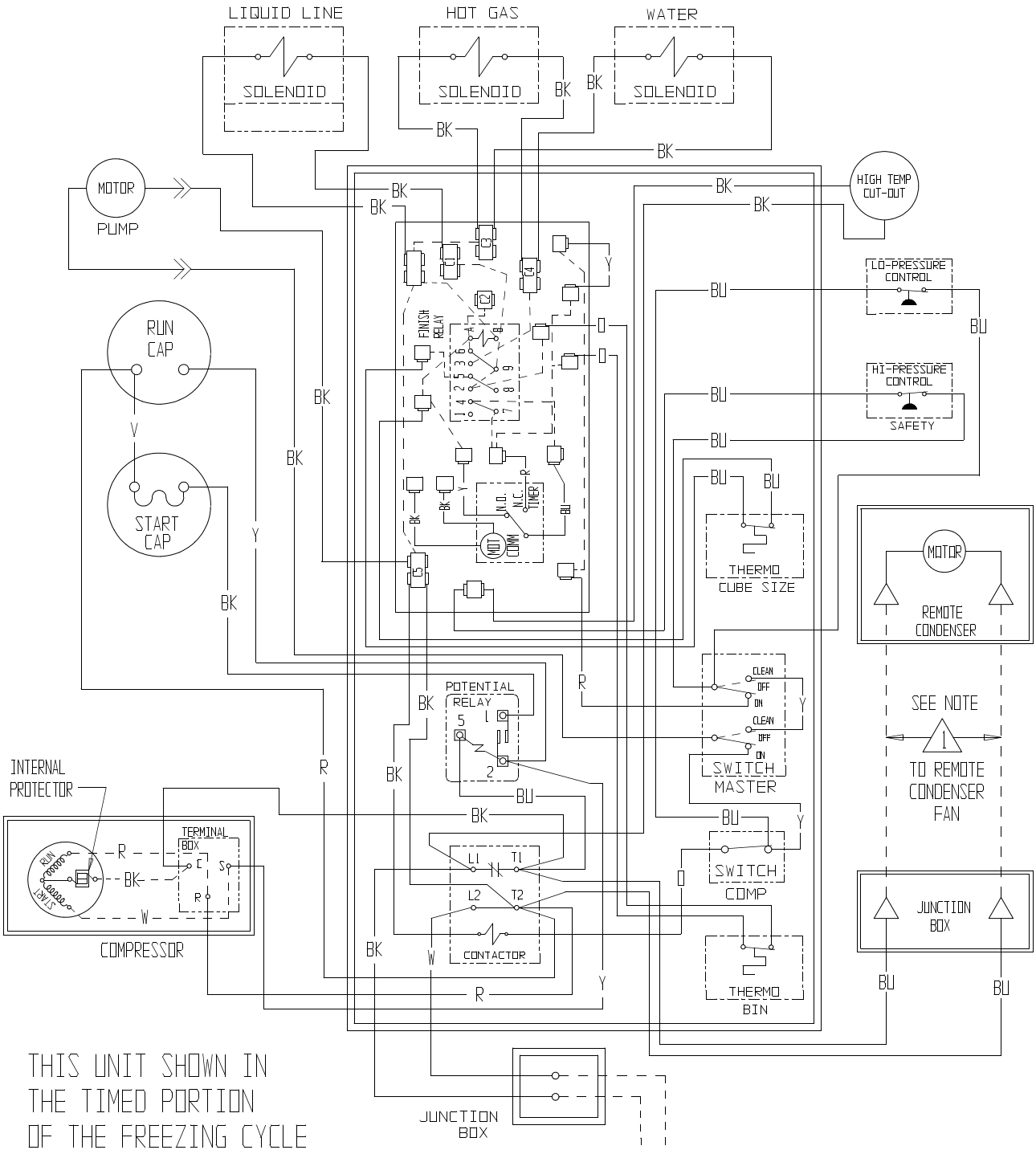

THIS UNIT SHOWN IN THE TIMED PORTION OF THE FREEZING CYCLE

USE COPPER CONDUCTORS ONLY

POWER SUPPLY:  
SEE NAMEPLATE FOR PROPER VOLTAGE REQUIREMENTS AND MAXIMUM FUSE SIZE



# CME650R SERVICE PARTS

## Single Phase SCHEMATIC DIAGRAM

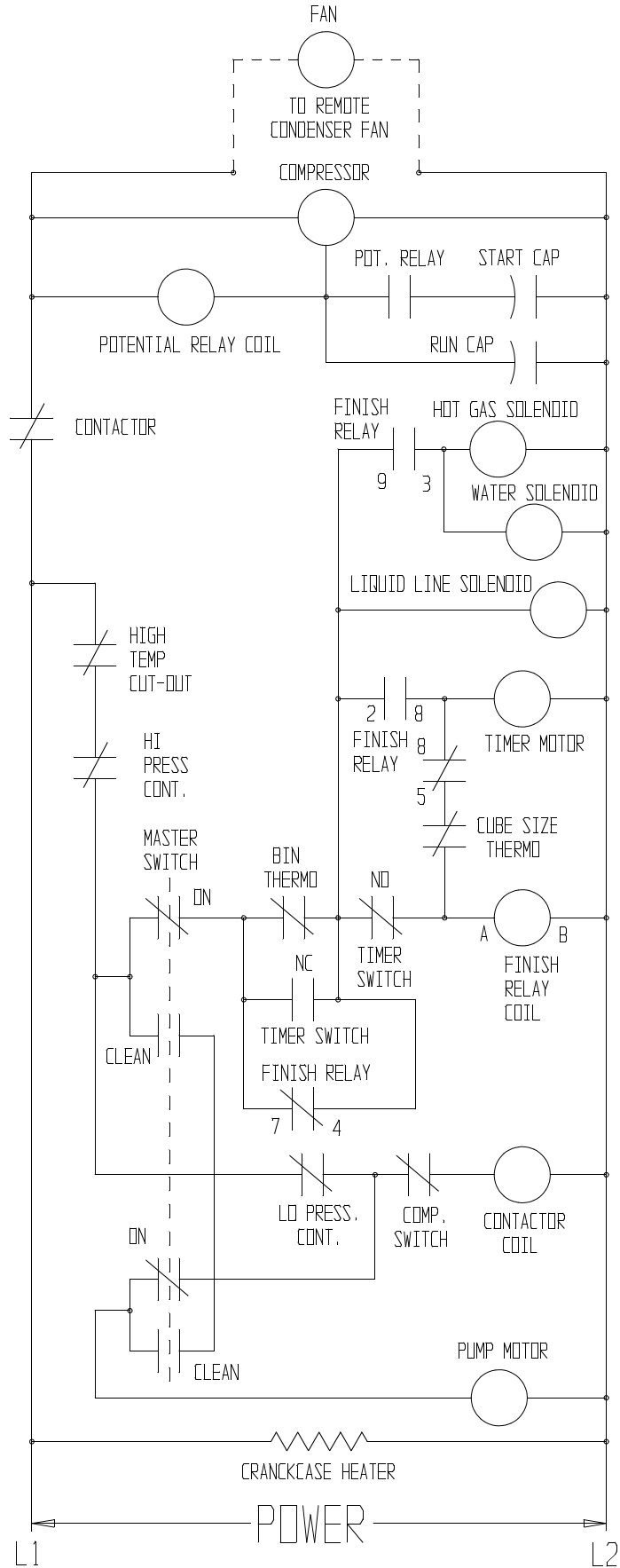

# CME650R SERVICE PARTS

## 3 Phase Wiring Diagram

A35941-003

THIS UNIT MUST BE GROUNDED

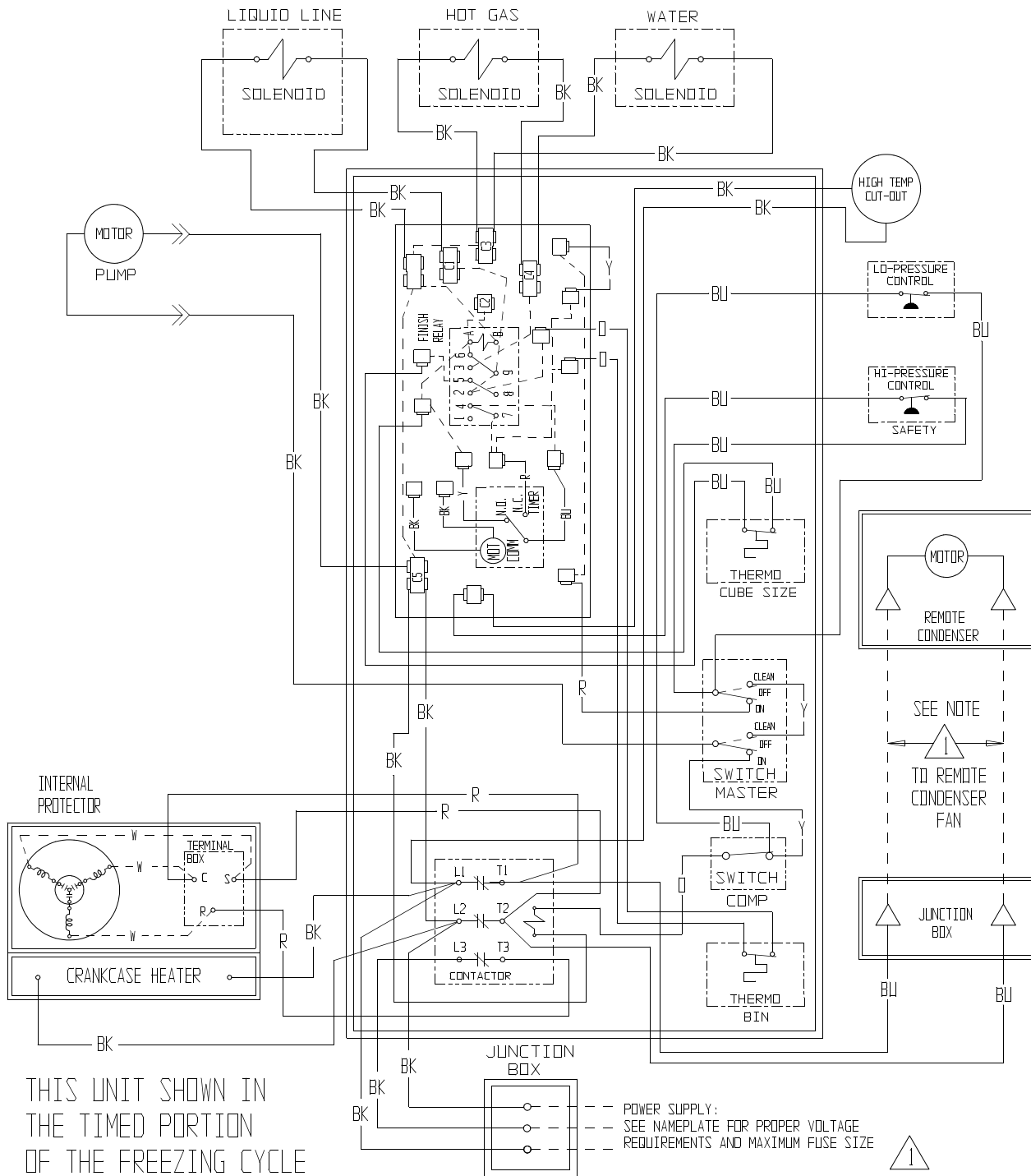

THIS UNIT SHOWN IN THE TIMED PORTION OF THE FREEZING CYCLE  
USE COPPER CONDUCTORS ONLY

# CME650R SERVICE PARTS

## 3 Phase Schematic Diagram

